

3" BORE STAINLESS STEEL CYLINDER



SDR-48-□-□

Double Acting



Mount: Stud **Standard Stroke Lengths:** 1", 2", 3", 4", 5", 6"
Type: Rotating Rod **Maximum Stroke:** 34"
Options: M, W, V, P6, P7, P8, S, N

Bumpers are standard
 No additional length for bumpers

For S option add 0.437

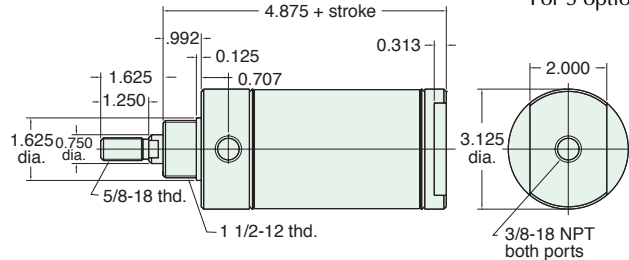

Nut included, but not shown on drawing

UDR-48-□-□

Double Acting



Mount: Universal **Standard Stroke Lengths:** 1", 2", 3", 4", 5", 6", 7", 8", 10", 12"
Type: Rotating Rod **Maximum Stroke:** 32"
Options: M, W, V, P2, P3, P4, P5, P6, P7, P8, N

Bumpers are standard
 No additional length for bumpers

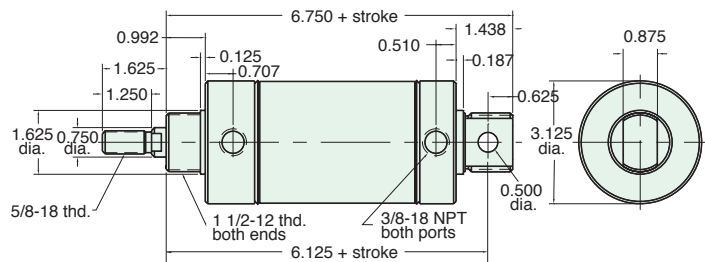

Furnished without nut(s). See Chart on Page 58.

SDD-48-□-□

Double Acting



Mount: Stud **Standard Stroke Lengths:** 1", 2", 3", 4", 5", 6", 8", 10", 12"
Type: Double Rod **Maximum Stroke:** 15"
Options: M, W, V, P6, P7, P8, N

Bumpers are standard
 No additional length for bumpers

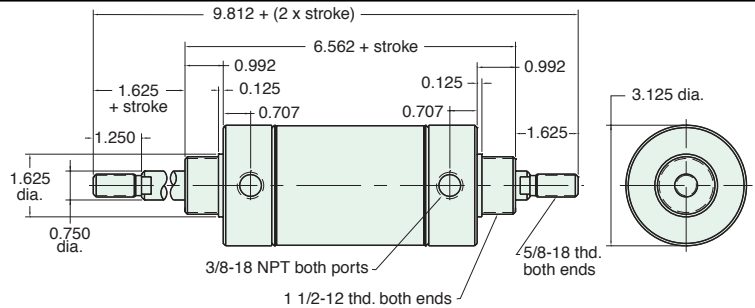

Nuts included, but not shown on drawing

Did you know...

Minimatic®, Maximatic®, Minimetric®, Fluidamp®, Octoport®, Air-2-Electric® and Air Force One® are all Clippard registered trademarks.

